



IMV VIBRATION
TEST SYSTEMS

A series

IMV-Smart™

ECO-Shaker

Air-cooled Vibration Test Systems

A11/EM1HAM



A series is the “new standard” in vibration testing, with a solid test performance. A series increases the relative excitation force and has a displacement of 3.0 in-p*1, which provides a good balance within the specifications for velocity, acceleration and displacement. It also provides a maximum of 138 in/s shock velocity testing, which responds to the demand in lithium battery testing. A series supports rapid creation of tests from a set of pre-defined templates conforming to most international test standards. Simply select the standard required to generate the main test settings.

*1) Only for A30, A45, A65, A74



1. Improvement of performance

Expansion of test cases and responses to high spec. tests allow the A series to meet a wide range of testing needs.

- Improvement in excitation force
- Standard 3.0 in-p displacement
- Expansion in frequency range
- High velocity shock test

2. User friendly and secure

Greater security and functionality with improved energy savings.

Comparison of consumed power per excitation force

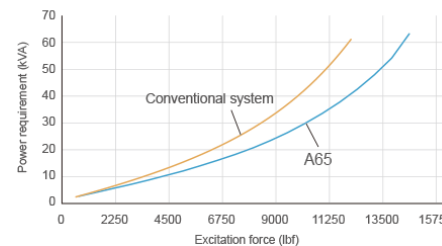

3. User first principle

Intuitive interface guides the operator for easy use.



IMV CORPORATION



IMV VIBRATION
TEST SYSTEMS

A series

IMV-Smart™
ECO-Shaker

Air-cooled Vibration Test Systems
A11/EM1HAM



System Specification		
Frequency Range (Hz)	0-4,500 ^{*4}	
Rated Force	Sine (lbf)	2,470
	Random (lbf rms) ^{*1}	2,470
	Shock (lbf)	4,945
	High Velocity Shock (lbf)	3,710
Maximum Acc.	Sine (g)	102
	Random (g rms)	65
	Shock (g peak)	204
	High Velocity Shock (g peak)	153
Maximum Vel.	Sine (in/s)	79
	Shock (in/s peak)	99
	High Velocity Shock (in/s peak)	136
Maximum Disp.	Sine (in-p)	2.0
	High Velocity Shock (in-p)	2.5
Maximum Travel (in-p)	2.5	
Maximum Load (lbs)	441	
Power Requirements (kVA) ^{*2}	20.4	
Breaker Capacity (A) ^{*3}	30	

Vibration Generator (A11)	
Armature Mass (lbs)	24
Armature Diameter (φ in)	8.3
Armature Resonance (Hz)	3,160
Allowance Eccentric Moment (lbf·in)	2,600
Mass (lbs)	2,381

Power Amplifier (EM1HAM-A11)	
Maximum Output (kVA)	12
Amplifier Bay	1
Mass (lbs)	1036

Cooling	
Mass (lbs)	309
Cooling Air Flow (cfm)	494

Environmental Data		
Input Voltage Supply (3 φ, V)	220/480	
Compressed Air Supply (psi)	102	
Working Ambient Temperature	Shaker (°F)	32-104
	Amplifier (°F)	32-104

*1) Random force ratings are specified in accordance with ISO5344 conditions. Please contact IMV or your local distributor with specific test requirements.
 *2) Power supply: 3-phase 220/480 V, 60 Hz. A transformer is required for other supply voltages.
 *3) Breaker capacity for 480 V.
 *4) Above 4,000 Hz, the force rolls-off at a rate of -6 dB/oct.
 * For random vibration tests, please set the test definition of the peak value of acceleration waveform to operate at less than the maximum acceleration of shock.
 * Frequency range values vary according to sensor and vibration controller.
 * Armature mass and acceleration may change when chamber is combined.

Vibration Generator (A11)

a: W 37 in
b: H 33 in
c: D 27 in

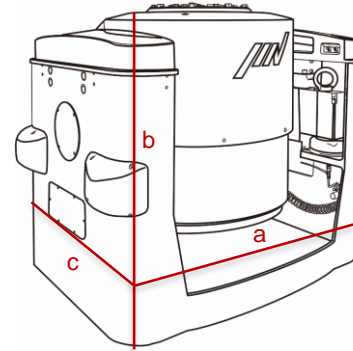
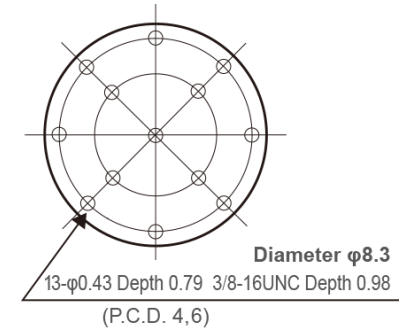
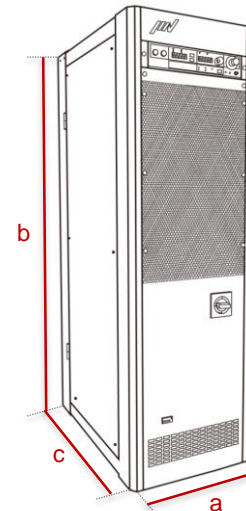

Table Insert Pattern (unit: inch)



Amplifier (EM1HAM-A11)

a: W 23 in
b: H 77 in
c: D 34 in



Blower

a: W 28 in
b: H 56 in
c: D 31 in

